



CAR FILLING



DISPENSERS



PUMPS



METERS



NOZZLE METERS



NOZZLES

SQUALO35

FEATURES

- **HEAVY DUTY**
- **REGENERATIVE TURBINE**
- **INTEGRATED PRESSURE REGULATOR**

SQUALO35 is the first submersible pump for AdBlue® to have been especially developed and tested for distribution systems. A centrifugal pump fitted with a turbine regenerator with non-return valve and a built-in innovative pressure regulation system that optimises flow rate performance levels. Consistent flow rate and accuracy during delivery dramatically reduce energy consumption levels. The compact size and special pump design make for easy installation and near-complete emptying of the intended installation tank.

PERFORMANCE

UP TO

35 L/MIN

FLOW RATE

AC V. / Hz

230/50

VOLTAGE

POWER

30 MM

DEAD LEVEL



SQUALO35

PACKAGING

CODE	WEIGHT		PACKAGING		
	KG	LBS	MM	INCH	PCS/BOX
FO0206010	7	15,4	510X240X150	20X9,4X5,6	1
FO0206020	7	15,4	510X240X150	20X9,4X5,6	1



FILTRATION



FLUID MONITORING



HOSE REELS



ACCESSORIES



MERCHANDISE



AIR



ANTIFREEZE



AdBlue®



BIODIESEL



DIESEL



FOOD



GASOLINE



GREASE



KEROSENE



OIL



WATER



WINDSCREEN

CHARTS



IN THE BOX

- SQUALO35
- INSTRUCTION MANUAL

DETAILS



MESH STRAINER

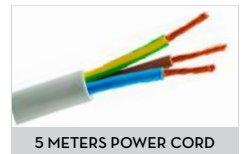

5 METERS POWER CORD

DIMENSIONS

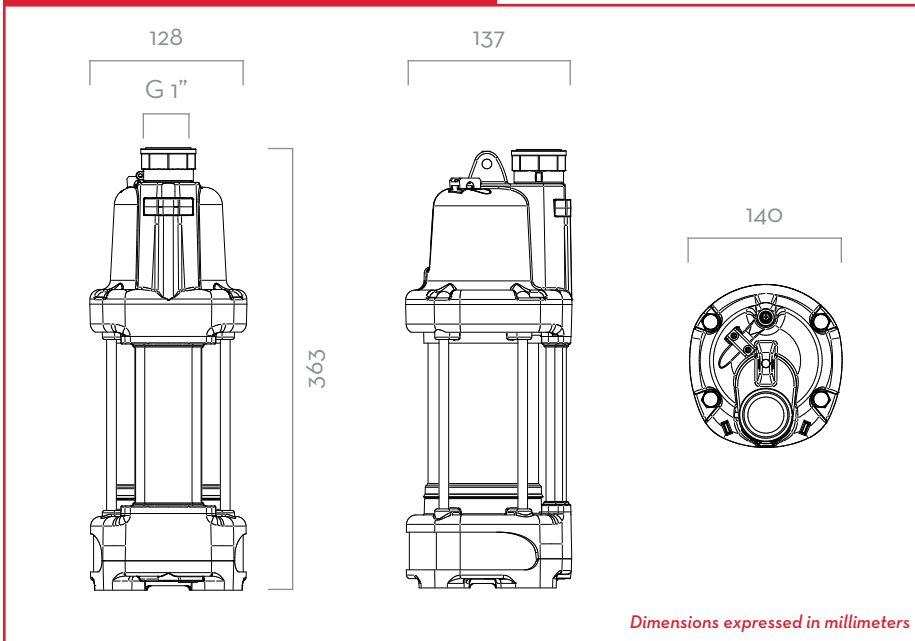

MATERIALS

- BODY: STAINLESS STEEL/TECHNOPOLYMER
- TURBINE: TECHNOPOLYMER

TECHNICAL DATA

CODICE	DESCRIPTION	FLUIDS TYPE	WORKING PRESSURE	FLOW-RATE		VOLTAGE		DEAD LEVEL	POWER CORD
				L/MIN	GPM	CA V/HZ CC V	WATT		
FOO206010	SQUALO35 230/50 BASIC	Ad W	1,8 BAR 27 PSI	35	7,7	230/50	560	30MM	5 M
FOO206020	SQUALO35 230/50 TIMER	Ad W	1,8 BAR 27 PSI	35	7,7	230/50	560	30 MM	5 M